

## Stehle Product Information

# NF - POSITIVE

## NF-CHOP SAW BLADES HW - POSITIVE HOOK ANGLE TRIPLE CHIP / FLAT, „TR-F“

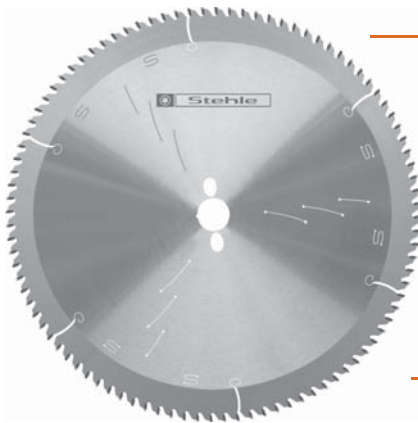

- table saws
- clipping and miter saws



- tooth configuration: triple chip /flat "TR-F"
- positive hook angle
- cutting material: HW TCm 10 from Ø 400 TC06

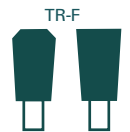

- noise-reduction thanks to laser ornaments

- for dividing and miter cuts in aluminum and plastic profiles, aluminum sheets on machines with workpiece clamping as well as wood-based panels

- **Notes:** tight workpiece clamping required



excellently suited for:  
aluminum, NF-metals,  
composite materials

Alu-Hollow profile:



well suited for:  
hermoplastic, thermoset, elastomeres,  
composite materials

HPL laminate:



Ø D [mm]	B [mm]	b [mm]	Ø d [mm]	Z	cutting material	NL	Hook angle[°]	Order-No.
250	3,2	2,5	30	80	TC 10	2/10/60 + 2/9/46 + 2/9,5/46,5 + 2/7/42	5	58808102
300	3,2	2,5	30	72	TC 10	2/10/60 + 2/9/46 + 2/9,5/46,5 + 2/7/42	5	58808104
300	3,2	2,5	30	96	TC 10	2/10/60 + 2/9/46 + 2/9,5/46,5 + 2/7/42	5	58808107
300	3,2	2,5	32	96	TC 10	4/12/64 +2/10/60 + 2/9/46 + 2/9,5/46,5 + 2/7/42	5	58808125
350	3,2	2,5	30	108	TC 10	2/10/60 + 2/9/46 + 2/9,5/46,5 + 2/7/42	5	58808111
400	3,8	3,2	30	96	TC 06	2/10/60 + 2/9/46 + 2/9,5/46,5 + 2/7/42	5	58808113
420	3,8	3,2	30	96	TC 06	2/10/60 + 2/9/46 + 2/9,5/46,5 + 2/7/42	5	58808115
450	3,8	3,2	40	108	TC 06	4/12/64 + 4/10/60	5	58808117
500	4,0	3,4	30	12	TC 06	4/12/64 + 4/10/60	5	58808118

Contact  
Stehle

T +49 (0) 7451 / 93 222  
F +49 (0) 7451 / 93 444

Date 02/2016

info@stehle-int.com  
www.stehle-int.com

## Stehle Product Information

# NF - NEGATIVE

## NF-CHOP SAW BLADES HW - NEGATIVE HOOK ANGLE TRIPLE CHIP / FLAT, „TR-F“



- clipping and miter saws



- tooth configuration: triple chip /flat "TR-F"

- negative hook angle

- cutting material: HW TCm 10  
from Ø 400 TC06

- noise-reduction thanks to laser ornaments

- for clipping and miter cuts in aluminum and plastic profiles

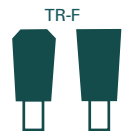

 excellently suited for:  
aluminum, NF-metals,  
composite materials

Alu-Hollow profile:

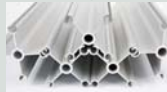

 well suited for:  
crylic boards, gypsum boards, cement-bound boards,  
thermosetting plastics, composite materials

Gypsum plaster board:

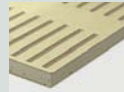

 well suited for:  
hermoplastic, thermoset, elastomeres,  
composite materials

HPL laminate:

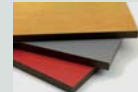

Ø D [mm]	B [mm]	b [mm]	Ø d [mm]	Z	cutting material	NL	Hook angle[°]	Order-No.
235	2,8	2,2	30	64	TC 10	2/7/42	-6	58115018
250	3,2	2,5	30	60	TC 10	2/10/60 + 2/9/46 + 2/9,5/46,5 + 2/7/42	-6	58808201
250	2,8	2,2	30	80	TC 10	2/10/60 + 2/9/46 + 2/9,5/46,5 + 2/7/42	-6	58808200
250	3,2	2,5	30	80	TC 10	2/10/60 + 2/9/46 + 2/9,5/46,5 + 2/7/42	-6	58808203
250	3,2	2,5	32	60	TC 10	2/10/60 + 2/9/46 + 2/9,5/46,5 + 2/7/42	-6	58808202
250	3,2	2,5	32	80	TC 10	2/10/60 + 2/9/46 + 2/9,5/46,5 + 2/7/42	-6	58808204
250	3,2	2,5	40	80	TC 10	4/12/64 + 2/9/55 + 2/10/60 + 2/9/46 + 2/9,5/46,5 + 2/7/42	-6	58808205
254	3,2	2,5	30	80	TC 10	2/10/60 + 2/9/46 + 2/9,5/46,5 + 2/7/42	-6	58808246
260	3,2	2,5	30	72	TC 10	2/10/60 + 2/9/46 + 2/9,5/46,5 + 2/7/42	-6	58808206
300	3,2	2,5	30	72	TC 10	2/10/60 + 2/9/46 + 2/9,5/46,5 + 2/7/42	-6	58808209
300	3,2	2,5	30	80	TC 10	2/10/60 + 2/9/46 + 2/9,5/46,5 + 2/7/42	-6	58808244
300	2,8	2,2	30	96	TC 10	2/10/60 + 2/9/46 + 2/9,5/46,5 + 2/7/42	-6	58808213
300	3,2	2,5	30	96	TC 10	2/10/60 + 2/9/46 + 2/9,5/46,5 + 2/7/42	-6	58808214
300	3,2	2,5	32	96	TC 10	4/12/64	-6	58808215
300	3,3	2,5	40	96	TC 10	4/12/64 + 2/9/55	-6	58808216
305	3,2	2,5	30	96	TC 10	2/10/60 + 2/9/46 + 2/9,5/46,5 + 2/7/42	-6	58808245
330	3,2	2,5	30	96	TC 10	2/10/60 + 2/9/46 + 2/9,5/46,5 + 2/7/42	-6	58808217
330	3,2	2,5	32	96	TC 10	2/10/60 + 2/9/46 + 2/9,5/46,5 + 2/7/42	-6	58808218
350	3,2	2,5	30	90	TC 10	2/10/60 + 2/9/46 + 2/9,5/46,5 + 2/7/42	-6	58808222
350	3,2	2,5	30	108	TC 10	2/10/60 + 2/9/46 + 2/9,5/46,5 + 2/7/42	-6	58808225
350	3,2	2,5	32	108	TC 10	4/12/64	-6	58808226
350	3,2	2,5	40	108	TC 10	4/12/64 + 2/9/55	-6	58808227
380	3,8	3,2	32	110	TC 10	4/12/64	-6	58808243
400	3,8	3,2	30	96	TC 10	2/10/60 + 2/9/46 + 2/9,5/46,5 + 2/7/42	-6	58808232
420	4,0	3,2	30	96	TC 06	2/10/60 + 2/9/46 + 2/9,5/46,5 + 2/7/42	-6	58808234
420	3,8	3,2	40	100	TC 06	4/12/64 + 2/9/55	-6	58808236
450	3,8	3,2	30	96	TC 06	4/12/64 + 2/12/80 + 2/10/60 + 2/9/46 + 2/9,5/46,5 + 2/7/42	-6	58808235
500	4,0	3,4	30	120	TC 06	4/12/64 + 2/10/60	-6	58808239